

Operator's Manual

CWT GFM[™]

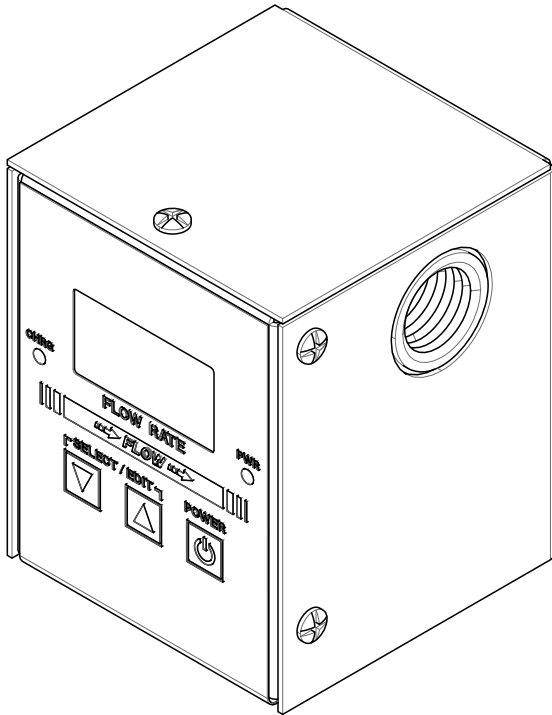

For use with machines having Numbers:
K3696-1, K3697-1



Register your machine:
www.lincolnelectric.com/register

Authorized Service and Distributor Locator:
www.lincolnelectric.com/locator

Save for future reference

Date Purchased

Code: (ex: 10859)

Serial: (ex: U1060512345)

THANK YOU FOR SELECTING A QUALITY PRODUCT BY LINCOLN ELECTRIC.

PLEASE EXAMINE CARTON AND EQUIPMENT FOR DAMAGE IMMEDIATELY

When this equipment is shipped, title passes to the purchaser upon receipt by the carrier. Consequently, claims for material damaged in shipment must be made by the purchaser against the transportation company at the time the shipment is received.

SAFETY DEPENDS ON YOU

Lincoln arc welding and cutting equipment is designed and built with safety in mind. However, your overall safety can be increased by proper installation ... and thoughtful operation on your part. **DO NOT INSTALL, OPERATE OR REPAIR THIS EQUIPMENT WITHOUT READING THIS MANUAL AND THE SAFETY PRECAUTIONS CONTAINED THROUGHOUT.** And, most importantly, think before you act and be careful.

WARNING

This statement appears where the information must be followed exactly to avoid serious personal injury or loss of life.

CAUTION

This statement appears where the information must be followed to avoid minor personal injury or damage to this equipment.



KEEP YOUR HEAD OUT OF THE FUMES.

DON'T get too close to the arc. Use corrective lenses if necessary to stay a reasonable distance away from the arc.

READ and obey the Safety Data Sheet (SDS) and the warning label that appears on all containers of welding materials.

USE ENOUGH VENTILATION or exhaust at the arc, or both, to keep the fumes and gases from your breathing zone and the general area.

IN A LARGE ROOM OR OUTDOORS, natural ventilation may be adequate if you keep your head out of the fumes (See below).

USE NATURAL DRAFTS or fans to keep the fumes away from your face.

If you develop unusual symptoms, see your supervisor. Perhaps the welding atmosphere and ventilation system should be checked.



WEAR CORRECT EYE, EAR & BODY PROTECTION

PROTECT your eyes and face with welding helmet properly fitted and with proper grade of filter plate (See ANSI Z49.1).

PROTECT your body from welding spatter and arc flash with protective clothing including woolen clothing, flame-proof apron and gloves, leather leggings, and high boots.

PROTECT others from splatter, flash, and glare with protective screens or barriers.

IN SOME AREAS, protection from noise may be appropriate.

BE SURE protective equipment is in good condition.

Also, wear safety glasses in work area **AT ALL TIMES.**



SPECIAL SITUATIONS

DO NOT WELD OR CUT containers or materials which previously had been in contact with hazardous substances unless they are properly cleaned. This is extremely dangerous.

DO NOT WELD OR CUT painted or plated parts unless special precautions with ventilation have been taken. They can release highly toxic fumes or gases.

Additional precautionary measures

PROTECT compressed gas cylinders from excessive heat, mechanical shocks, and arcs; fasten cylinders so they cannot fall.

BE SURE cylinders are never grounded or part of an electrical circuit.

REMOVE all potential fire hazards from welding area.

ALWAYS HAVE FIRE FIGHTING EQUIPMENT READY FOR IMMEDIATE USE AND KNOW HOW TO USE IT.



SECTION A: WARNINGS



CALIFORNIA PROPOSITION 65 WARNINGS

Diesel Engines

Diesel engine exhaust and some of its constituents are known to the State of California to cause cancer, birth defects, and other reproductive harm.

Gasoline Engines

The engine exhaust from this product contains chemicals known to the State of California to cause cancer, birth defects, or other reproductive harm.

ARC WELDING CAN BE HAZARDOUS. PROTECT YOURSELF AND OTHERS FROM POSSIBLE SERIOUS INJURY OR DEATH. KEEP CHILDREN AWAY. PACEMAKER WEARERS SHOULD CONSULT WITH THEIR DOCTOR BEFORE OPERATING.

Read and understand the following safety highlights. For additional safety information, it is strongly recommended that you purchase a copy of "Safety in Welding & Cutting - ANSI Standard Z49.1" from the American Welding Society, P.O. Box 351040, Miami, Florida 33135 or CSA Standard W117.2-1974. A Free copy of "Arc Welding Safety" booklet E205 is available from the Lincoln Electric Company, 22801 St. Clair Avenue, Cleveland, Ohio 44117-1199.

BE SURE THAT ALL INSTALLATION, OPERATION, MAINTENANCE AND REPAIR PROCEDURES ARE PERFORMED ONLY BY QUALIFIED INDIVIDUALS.



FOR ENGINE POWERED EQUIPMENT.

- 1.a. Turn the engine off before troubleshooting and maintenance work unless the maintenance work requires it to be running.



- 1.b. Operate engines in open, well-ventilated areas or vent the engine exhaust fumes outdoors.

- 1.c. Do not add the fuel near an open flame welding arc or when the engine is running. Stop the engine and allow it to cool before refueling to prevent spilled fuel from vaporizing on contact with hot engine parts and igniting. Do not spill fuel when filling tank. If fuel is spilled, wipe it up and do not start engine until fumes have been eliminated.



- 1.d. Keep all equipment safety guards, covers and devices in position and in good repair. Keep hands, hair, clothing and tools away from V-belts, gears, fans and all other moving parts when starting, operating or repairing equipment.



- 1.e. In some cases it may be necessary to remove safety guards to perform required maintenance. Remove guards only when necessary and replace them when the maintenance requiring their removal is complete. Always use the greatest care when working near moving parts.

- 1.f. Do not put your hands near the engine fan. Do not attempt to override the governor or idler by pushing on the throttle control rods while the engine is running.

- 1.g. To prevent accidentally starting gasoline engines while turning the engine or welding generator during maintenance work, disconnect the spark plug wires, distributor cap or magneto wire as appropriate.

- 1.h. To avoid scalding, do not remove the radiator pressure cap when the engine is hot.



ELECTRIC AND MAGNETIC FIELDS MAY BE DANGEROUS

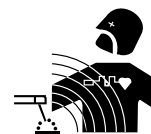

- 2.a. Electric current flowing through any conductor causes localized Electric and Magnetic Fields (EMF). Welding current creates EMF fields around welding cables and welding machines
- 2.b. EMF fields may interfere with some pacemakers, and welders having a pacemaker should consult their physician before welding.
- 2.c. Exposure to EMF fields in welding may have other health effects which are now not known.
- 2.d. All welders should use the following procedures in order to minimize exposure to EMF fields from the welding circuit:
- 2.d.1. Route the electrode and work cables together - Secure them with tape when possible.
 - 2.d.2. Never coil the electrode lead around your body.
 - 2.d.3. Do not place your body between the electrode and work cables. If the electrode cable is on your right side, the work cable should also be on your right side.
 - 2.d.4. Connect the work cable to the workpiece as close as possible to the area being welded.
 - 2.d.5. Do not work next to welding power source.



ELECTRIC SHOCK CAN KILL.



- 3.a. The electrode and work (or ground) circuits are electrically “hot” when the welder is on. Do not touch these “hot” parts with your bare skin or wet clothing. Wear dry, hole-free gloves to insulate hands.
- 3.b. Insulate yourself from work and ground using dry insulation. Make certain the insulation is large enough to cover your full area of physical contact with work and ground.

In addition to the normal safety precautions, if welding must be performed under electrically hazardous conditions (in damp locations or while wearing wet clothing; on metal structures such as floors, gratings or scaffolds; when in cramped positions such as sitting, kneeling or lying, if there is a high risk of unavoidable or accidental contact with the workpiece or ground) use the following equipment:

- Semiautomatic DC Constant Voltage (Wire) Welder.
 - DC Manual (Stick) Welder.
 - AC Welder with Reduced Voltage Control.
- 3.c. In semiautomatic or automatic wire welding, the electrode, electrode reel, welding head, nozzle or semiautomatic welding gun are also electrically “hot”.
 - 3.d. Always be sure the work cable makes a good electrical connection with the metal being welded. The connection should be as close as possible to the area being welded.
 - 3.e. Ground the work or metal to be welded to a good electrical (earth) ground.
 - 3.f. Maintain the electrode holder, work clamp, welding cable and welding machine in good, safe operating condition. Replace damaged insulation.
 - 3.g. Never dip the electrode in water for cooling.
 - 3.h. Never simultaneously touch electrically “hot” parts of electrode holders connected to two welders because voltage between the two can be the total of the open circuit voltage of both welders.
 - 3.i. When working above floor level, use a safety belt to protect yourself from a fall should you get a shock.
 - 3.j. Also see Items 6.c. and 8.



ARC RAYS CAN BURN.



- 4.a. Use a shield with the proper filter and cover plates to protect your eyes from sparks and the rays of the arc when welding or observing open arc welding. Headshield and filter lens should conform to ANSI Z87.1 standards.
- 4.b. Use suitable clothing made from durable flame-resistant material to protect your skin and that of your helpers from the arc rays.
- 4.c. Protect other nearby personnel with suitable, non-flammable screening and/or warn them not to watch the arc nor expose themselves to the arc rays or to hot spatter or metal.



FUMES AND GASES CAN BE DANGEROUS.

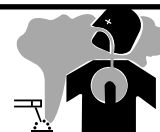

- 5.a. Welding may produce fumes and gases hazardous to health. Avoid breathing these fumes and gases. When welding, keep your head out of the fume. Use enough ventilation and/or exhaust at the arc to keep fumes and gases away from the breathing zone. **When welding hardfacing (see instructions on container or SDS) or on lead or cadmium plated steel and other metals or coatings which produce highly toxic fumes, keep exposure as low as possible and within applicable OSHA PEL and ACGIH TLV limits using local exhaust or mechanical ventilation unless exposure assessments indicate otherwise. In confined spaces or in some circumstances, outdoors, a respirator may also be required. Additional precautions are also required when welding on galvanized steel.**
- 5.b. The operation of welding fume control equipment is affected by various factors including proper use and positioning of the equipment, maintenance of the equipment and the specific welding procedure and application involved. Worker exposure level should be checked upon installation and periodically thereafter to be certain it is within applicable OSHA PEL and ACGIH TLV limits.
- 5.c. Do not weld in locations near chlorinated hydrocarbon vapors coming from degreasing, cleaning or spraying operations. The heat and rays of the arc can react with solvent vapors to form phosgene, a highly toxic gas, and other irritating products.
- 5.d. Shielding gases used for arc welding can displace air and cause injury or death. Always use enough ventilation, especially in confined areas, to insure breathing air is safe.
- 5.e. Read and understand the manufacturer’s instructions for this equipment and the consumables to be used, including the Safety Data Sheet (SDS) and follow your employer’s safety practices. SDS forms are available from your welding distributor or from the manufacturer.
- 5.f. Also see item 1.b.



WELDING AND CUTTING SPARKS CAN CAUSE FIRE OR EXPLOSION.

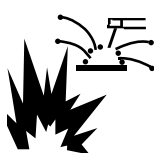

- 6.a. Remove fire hazards from the welding area. If this is not possible, cover them to prevent the welding sparks from starting a fire. Remember that welding sparks and hot materials from welding can easily go through small cracks and openings to adjacent areas. Avoid welding near hydraulic lines. Have a fire extinguisher readily available.
- 6.b. Where compressed gases are to be used at the job site, special precautions should be used to prevent hazardous situations. Refer to "Safety in Welding and Cutting" (ANSI Standard Z49.1) and the operating information for the equipment being used.
- 6.c. When not welding, make certain no part of the electrode circuit is touching the work or ground. Accidental contact can cause overheating and create a fire hazard.
- 6.d. Do not heat, cut or weld tanks, drums or containers until the proper steps have been taken to insure that such procedures will not cause flammable or toxic vapors from substances inside. They can cause an explosion even though they have been "cleaned". For information, purchase "Recommended Safe Practices for the Preparation for Welding and Cutting of Containers and Piping That Have Held Hazardous Substances", AWS F4.1 from the American Welding Society (see address above).
- 6.e. Vent hollow castings or containers before heating, cutting or welding. They may explode.
- 6.f. Sparks and spatter are thrown from the welding arc. Wear oil free protective garments such as leather gloves, heavy shirt, cuffless trousers, high shoes and a cap over your hair. Wear ear plugs when welding out of position or in confined places. Always wear safety glasses with side shields when in a welding area.
- 6.g. Connect the work cable to the work as close to the welding area as practical. Work cables connected to the building framework or other locations away from the welding area increase the possibility of the welding current passing through lifting chains, crane cables or other alternate circuits. This can create fire hazards or overheat lifting chains or cables until they fail.
- 6.h. Also see item 1.c.
- 6.i. Read and follow NFPA 51B "Standard for Fire Prevention During Welding, Cutting and Other Hot Work", available from NFPA, 1 Batterymarch Park, PO box 9101, Quincy, MA 02269-9101.
- 6.j. Do not use a welding power source for pipe thawing.

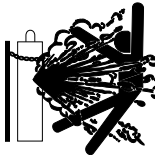

CYLINDER MAY EXPLODE IF DAMAGED.

- 7.a. Use only compressed gas cylinders containing the correct shielding gas for the process used and properly operating regulators designed for the gas and pressure used. All hoses, fittings, etc. should be suitable for the application and maintained in good condition. 
- 7.b. Always keep cylinders in an upright position securely chained to an undercarriage or fixed support.
- 7.c. Cylinders should be located:
 - Away from areas where they may be struck or subjected to physical damage.
 - A safe distance from arc welding or cutting operations and any other source of heat, sparks, or flame.
- 7.d. Never allow the electrode, electrode holder or any other electrically "hot" parts to touch a cylinder.
- 7.e. Keep your head and face away from the cylinder valve outlet when opening the cylinder valve.
- 7.f. Valve protection caps should always be in place and hand tight except when the cylinder is in use or connected for use.
- 7.g. Read and follow the instructions on compressed gas cylinders, associated equipment, and CGA publication P-1, "Precautions for Safe Handling of Compressed Gases in Cylinders," available from the Compressed Gas Association, 14501 George Carter Way Chantilly, VA 20151.



FOR ELECTRICALLY POWERED EQUIPMENT.



- 8.a. Turn off input power using the disconnect switch at the fuse box before working on the equipment.
- 8.b. Install equipment in accordance with the U.S. National Electrical Code, all local codes and the manufacturer's recommendations.
- 8.c. Ground the equipment in accordance with the U.S. National Electrical Code and the manufacturer's recommendations.

Refer to
<http://www.lincolnelectric.com/safety>
for additional safety information.

Table of Contents

1.0 OVERVIEW.....	1
1.1 DESCRIPTION.....	1
1.2 BENEFITS.....	1
1.3 FEATURES.....	1
1.4 MECHANICAL SPECIFICATIONS.....	1
1.5 SENSOR SPECIFICATIONS.....	2
1.6 MODELS.....	2
1.7 OPTIONAL ACCESSORIES.....	2
2.0 INSTALLATION.....	3
2.1 OPTIONS.....	3
2.2 GAS LINE HOOKUP.....	3
2.3 CABLE HOOKUP.....	3
2.4 GAS FLOW LIMITS.....	4
2.5 GAS FLOW VOLUME.....	4
3.0 OPERATION.....	5
3.1 FIRMWARE VERSION.....	5
3.2 PROGRAM LIMITS.....	5
3.3 PARAMETERS.....	6
4.0 SETTING GAS FLOW CONTROL LIMITS.....	9
4.1 DESCRIPTION.....	9
4.2 SETUP.....	9
5.0 GAS FLOW SURGE “PEAK” MEASUREMENT.....	10
5.1 DESCRIPTION.....	10
5.2 SETUP.....	10
6.0 GAS FLOW USAGE LOG.....	11
6.1 DESCRIPTION.....	11
6.2 SETUP.....	11
6.3 RESET LOG MODE CLOCK.....	11
6.4 RESET LOG MODE VOLUME.....	12
7.0 GFM CONNECTOR PIN ASSIGNMENT.....	13
7.1 AUX CONNECTOR.....	13
8.0 POWER OPTIONS AND BATTERY SPECIFICATION/CHANGING.....	14
8.1 POWER OPTIONS.....	14
8.2 BATTERY SPECIFICATIONS.....	15
8.3 CHANGING THE BATTERY.....	16
9.0 MODEL SPECIFICATIONS.....	17
9.1 120/240 VAC PORTABLE GFM™ SYSTEM P/N: K3696-1.....	17
9.2 120/240 VAC IN-LINE GFM™ SYSTEM P/N: K3697-1.....	18
10.0 GFM ENCLOSURE SPECIFICATIONS.....	19
10.1 GFM™ ENCLOSURE PARTS LIST.....	19

10.2	GFM™ MOUNTING DIMENSIONS	20
11.0	CABLE SPECIFICATIONS	22
11.1	GFM™ AUX CABLE P/N: K3698-1	22
12.0	MODBUS SPECIFICATIONS.....	23
12.1	GFM MODBUS REGISTER DATA	23
12.2	MODBUS COILS CR [1..16]	23
12.3	MODBUS REGISTER REG [1..10]	24
12.4	MODBUS SERIAL PORT CONNECTIONS.....	24

1.0 OVERVIEW

1.1 Description

The Gas Flow Monitor (GFM™) is designed to precisely measure the flow rates of welding shielding gases. **WARNING – DO NOT USE WITH ANY FLAMMABLE GASES.** The unit comes in both "portable" and "in-line" models and is software configurable for English or Metric units of measure. The portable version can be used to check the gas flow rates directly at the welding torch. The unit is battery powered (and rechargeable) which allows it to be carried throughout the shop. This version is ideal for use by maintenance personnel to correctly set and verify shielding gas flow rates at the welding torch. **The GFM™ has 6 selectable gas settings, ARGON, Argon/ CO₂ (90/10), Argon/ CO₂ (80/20), Argon/ CO₂ (75/25), Helium, and CO₂. The GFM™ can be custom ordered and configured for additional gas mixtures.**

1.2 Benefits

The "in-line" version is designed to be permanently installed in a welding fixture to continuously monitor the gas flow rate. When used in this manner the GFM™ can provide "sure-flow" gas testing by setting upper and lower control limits for the user defined gas flow rates. An internal fault relay can be used to warn or interrupt the welding process if an out-of-limits condition is detected.

1.3 Features

Some of the features contained in the unit are the capability to limit test, provide an accumulated gas usage and peak flow rates as well as displaying on-going gas flow rates. The unit also provides an analog output voltage representing measured gas flow rates. The GFM™ also has a Modbus® RS-485 serial port. The sensor can communicate with third party controllers via the Modbus® protocol. The sensor defines 16 coils and 10 Registers for use with the Modbus® serial port. See the serial communications section for further descriptions of the feature. The GFM™ uses an OLED graphic display panel to display the gas flow rates, to provide programming menus and user defined optional parameter display.

1.4 Mechanical Specifications

Dimensions	2-13/16"W x 3-1/2"H x 2-13/16"L (71.4 mm W x 88.9 mm H x 71.4 mm L)
Weight	19 oz. (539 gm)
Pipe Fittings	3/8" NPT with 3/8" hose barb fittings recommended max torque 15 in. lbs.

1.5 Sensor Specifications

Measurement Range	5 - 255 CFH (2 - 120 LPM)
Display Resolution	±1 CFH (± 1 LPM)
Accuracy	±3 % of full-scale ±1 digit
Operating Pressure	50-PSI maximum (344 KPA)
Fault Relay Output	Opto-Isolated Solid State Relay (N.O. Contacts)
Relay Rating	48 vac @ 0.5 amps non-inductive 48 vdc @ 1.0 amps non-inductive
Analog Sensor Output	0 - 2.55 vdc @ 10 ma.
Analog Scaling	0.01 vdc = 1 CFH (0.01 V = 1 LPM)
Power Requirement	12 - 28 vdc @ 100 ma.
Operating Temperature	14° to 140° F (-10° to 60° C)
Battery Charger	120 vac 60 hz @ 300 ma (220 VAC 50 hz @ 300 ma)
Battery Life	Approximately 24 hours with full charge

(User configurable English / Metric units of measurement)

Note: Specifications subject to change without notification.

1.6 Models

The following models are covered in this document:

Part No.	Description
K3696-1	120/240 VAC Portable GFM™ System
K3697-1	120/240 VAC In-Line GFM™ System

1.7 Optional Accessories

Part No.	Description
K3698-1	AUX Cable for GFM™

2.0 INSTALLATION

2.1 Options

The GFM™ can be used as a portable or in-line gas flow monitor. If the unit was purchased as a portable monitor, it will be equipped with a rubber gas cone. When installing the rubber hose and gas cone on the GFM™ make sure the hose is installed on the side of the GFM™ marked gas inlet. The cone is designed to fit standard torch gas cups and allows the GFM™ to measure the actual gas flow at the torch. To install, simply press the GFM™ gas cone onto the welding torch gas cup. Make sure that the cone is fitted snugly to the gas cup. The GFM™ uses a custom MEM sensor that is calibrated to measure Air. **The GFM™ has 6 selectable gas settings, ARGON, Argon/ CO₂ (90/10), Argon/ CO₂ (80/20), Argon/ CO₂ (75/25), Helium, and CO₂.** The GFM™ can be custom ordered and configured for additional gas mixtures. By default the Argon gas type is enabled. To change the gas type, refer to the [Section 3: Operations](#).

2.2 Gas Line Hookup

The GFM may also be installed into the gas line and used to permanently monitor the gas-flow rate. This model is supplied with barbed 3/8 ID hose fittings. The sensor will accept any 3/8" NPT pipefitting. The user may hard plumb the sensor if desired. **DO NOT USE PIPE DOPE OR TEFLON TAPE ON THE PIPE FITTINGS.** The sensor should be located between the welding-gas solenoid and the torch. **DO NOT INSTALL THE SENSOR ON THE INLET SIDE OF THE GAS SOLENOID.** If the sensor is installed on the inlet pressure side of the gas solenoid, the maximum operating pressure (50 psi) of the transducer may be exceeded.

WARNING: Do not over tighten fittings as it may damage the sensor. The maximum recommended torque for fittings is 15 in. lbs or 1.7 newton meters

2.3 Cable Hookup

The GFM provides an analog voltage, which will represent gas flow. This analog voltage can be monitored by using the Auxiliary cable and connecting the plug to the "AUX" connector on the bottom panel. The output voltage will have the following relationship:

$$\begin{aligned} 2.55 \text{ volts} &= 255 \text{ scfh} \\ &\text{or} \\ 0.01 \text{ volt/scfh} \end{aligned}$$

The output impedance of this signal is 100 ohms and can source 10 milliamps of current. The analog-interface cable can also be used to supply power to the GFM™.

The power requirement is (12 - 28) vdc @ 100 ma. This cable also has the connections for the Fault Relay and Modbus® RS-485 serial port.

The following is the pin out for the GFM™ AUX Cable (P/N: K3698-1).

Pin No.	Function
1 (WHT)	Modbus RS-485 D+ serial port
2 (BRN)	User supplied Power Input VIN+ (12-28 VDC @100 ma)
3 (GRN)	CR-A - Will be active when gas flow is within programmed limits.
4 (YEL)	CR-B – Will be active when gas flow is within programmed limits.
5 (GRY)	User supply power common VCOM
6 (PNK)	Modbus RS485 and Vout analog common
7 (BLU)	Modbus RS-485 D- serial port
8 (RED)	Gas Flow Analog output VOUT+ (0.00 – 2.55 vdc)

2.4 Gas Flow Limits

The GFM™ can be used to test for High/Low gas flow limits. An internal fault relay will be set (CLOSED) when the gas flow is within the programmed limits. The fault relay can be interfaced to an external weld fixture controller.

2.5 Gas Flow Volume

The GFM™ can also be used to monitor accumulated gas flow and to provide an indication when the volume in a gas cylinder has reached a programmed minimum limit. The GFM™ will calculate the volume of gas used based on the measure flow rate. If the user programs the minimum volume for safe operation, the GFM™ will indicate when the estimate minimum volume has been reached. The GFM™ will set a fault relay when the estimated volume has decreased below the programmed minimum. Setting the starting volume “V” to 0 disables the function.

NOTE: THE LOW GAS VOLUME FAULT WILL NOT ACTIVATE THE FAULT RELAY BUT WILL INDICATE THE FAULT CONDITION BY SETTING A MODBUS® COIL CR15.

3.0 OPERATION

3.1 Firmware Version

The GFM™ is supplied with a plug-in the wall transformer, which powers the GFM™ and will also charge the optional internal battery. Plug the transformer into a suitable ac receptacle, and connect the power cable into the "POWER" jack located on the bottom panel of the GFM™. Press the power switch on the front panel "ON". The "POWER" LED will light and the following power up message will be displayed:

***** GFM *****
P/N A5Z0055 Ver #.##
Copyright (c) 2011
CWT, a Lincoln
Electric Brand
All Rights Reserved

Where: #.## is the firmware version number

Followed by the run time display:

0 CFH

Note: CFH will be replaced with LPH in metric mode

Activate the gas solenoid for the welding torch. The GFM™ will now display the gas flow rate in CFH (Cubic Feet per Hour) or LPM (Liters per Minute).

NOTE: When using the portable model, ensure no wire is fed while the cone is attached to the gas cup.

3.2 Program Limits

To program the High/Low limits and test parameters press both "▼" and "▲" switch simultaneously to enter the "**Select Para INC/DEC**" mode. The first programmable parameter will appear on the display. To increment through the program menus press the "▲" button. To decrement through the menus press the "▼" button. To edit a menu option press both "▼" and "▲" switch simultaneously to enter the "**Edit Para INC/DEC**" mode. To increment the parameter press the "▲" button. To decrement the parameter press the "▼" button. To end the "**Edit Para INC/DEC**" press both "▼" and "▲" switch simultaneously to exit and return to the normal display mode. The user can edit only one parameter at a time. To edit other parameters repeat the above sequence.

3.3 Parameters

The following is the list of the parameters and system configurations that can be modified by the user:

- **Max Limit= ###** - Maximum gas flow Limits. This value is used to set the high fault alarm and disable the output alarm. This value is also used to trigger the Peak Flow detector. The Peak flow value is updated and the peak flow time is incremented when the flow rate is greater than this limit. (Value range 5 – 255)
- **MIN Limit= ###** - Minimum gas flow rate limits. This limit in conjunction with the test delay time is used to set the Low Fault alarm and to disable the output alarm. When the flow is detected the Test delay timer is decremented and when the user defined delay time is reached the Low limit is tested and the output relay will be disabled if the flow rate is below this limit. (Value range 5 to 100)
- **Test Delay= ##.#** - This is the time in seconds that the GFM will wait before testing for a Low or High limit fault following an initial detection of gas flow. (Value range 0.5 to 10.0 seconds)
- **Enable Alarms?** - Allows the user to enable or disable the High Low limit testing. Setting this option to “No” will disable the alarm relay output. Setting this option to “Yes” will enable the alarm relay output. (Status Yes or No)
- **Enable Peak?** – Setting this parameter to yes will enable the Peak Flow display. When enabled an additional “**Peak= ### *.** sec**” display will be active. Where **###** is the last peak flow rate measured and “****.****” is the Total time at peak flow. The time at peak is the total time measured above the High limit value. The Peak is the peak flow measured above the High Limit. The peak value and time is reset at the start of the next detected gas flow period. This peak display will remain on the display until the peak is set to “**No**”.
- **Log Mode?** – Setting this parameter to yes will enable the flow volume accumulator and it will enable the “**Tot Volume= ##.#**” and the “**Total Time= HR:MN:SS**” display. Where **##.#** is the total accumulated volume and **HR:MN:SS** is the total time of gas flow since the last user reset. When disabled the volume display will be inactive and the gas flow accumulator will be disabled.
- **Metric Units?** – This parameter is used to select the units of measure for the gas flow rate. When set to “Yes” the units of measure is in Liters per Minute (LPM). When set to no, the units of measure are standard Cubic Feet per Hour (CFH).

- **DEVICE ID=** - This parameter sets the Modbus address ID number for the GFM. This address is used to identify the Device when using the Modbus® serial communications protocol. Each sensor connected to the Modbus® network must have a unique ID number assigned. (Value Range 1 to 247)
- **Clear Log Timer?** – This Option is used to reset the accumulated gas flow timer used when the log option is enabled. When set to “Yes” the timer will be reset to 00:00:00.
- **Reset Volume?** – This option is used to reset the gas volume accumulator to zero. The accumulator is used when the Log mode is set to yes. Setting this option to “Yes” will clear the accumulated volume of gas to zero.
- **Filter TC = ##** - The parameter sets the filter time constant for the displayed gas flow. Increasing this value will decrease the fluctuation in the gas flow reading. This filter does not impact the peak readings or accumulated flow parameters. (Value Range from 1 to 255).
- **Argon Gas?** - Allows the user to enable or disable Argon Gas conversion factor. Setting this option to “No” will disable the Argon Gas conversion factor. Setting this option to “Yes” will enable the Argon Gas conversion factor. (Status Yes or No) **Note:** *Disabling all Gas types (set to NO) will enable the Air conversion factor.*
- **CO₂ Gas?** - Allows the user to enable or disable CO₂ Gas conversion factor. Setting this option to “No” will disable the CO₂ Gas conversion factor. Setting this option to “Yes” will enable the CO₂ Gas conversion factor. (Status Yes or No) **Note:** *Disabling All Gas types (set to NO) will enable the Air conversion factor.*
- **Helium Gas?** - Allows the user to enable or disable Helium Gas conversion factor. Setting this option to “No” will disable the Helium Gas conversion factor. Setting this option to “Yes” will enable the Helium Gas conversion factor. (Status Yes or No) **Note:** *Disabling All Gas types (set to NO) will enable the Air conversion factor.*
- **75/25 Argon/ CO₂ Gas?** - Allows the user to enable or disable 75/25 Argon/ CO₂ Gas conversion factor. Setting this option to “No” will disable the 75/25 Argon/ CO₂ Gas conversion factor. Setting this option to “Yes” will enable the 75/25 Argon/ CO₂ Gas conversion factor. (Status Yes or No) **Note:** *Disabling All Gas types (set to NO) will enable the Air conversion factor.*

- **80/20 Argon/ CO₂ Gas?** - Allows the user to enable or disable 80/20 Argon/ CO₂ Gas conversion factor. Setting this option to “No” will disable the 80/20 Argon/ CO₂ Gas conversion factor. Setting this option to “Yes” will enable the 80/20 Argon/ CO₂ Gas conversion factor. (Status Yes or No) **Note:** *Disabling All Gas types (set to NO) will enable the Air conversion factor.*
- **90/10 Argon/ CO₂ Gas?** - Allows the user to enable or disable 90/10 Argon/ CO₂ Gas conversion factor. Setting this option to “No” will disable the 90/10 Argon/ CO₂ Gas conversion factor. Setting this option to “Yes” will enable the 90/10 Argon/ CO₂ Gas conversion factor. (Status Yes or No) **Note:** *Disabling All Gas types (set to NO) will enable the Air conversion factor.*

4.0 SETTING GAS FLOW CONTROL LIMITS

4.1 Description

To use the GFM as a Sure-Flow gas switch, the user can set the ***“Max Limit”*** and ***“Min Limit”***.

The GFM will activate the internal fault relay as long as the gas flow remains above the lower limit and below the upper limit. If the gas flow rate moves outside of the control limits the fault relay will be deactivated. The ***“Test Delay”*** parameter is used to delay the start of high limit testing. The value of this parameter will determine when the GFM will begin testing for the upper control limit after the gas flow is initiated. The lower limit is always being checked during the gas flow period. A high gas flow fault will only occur after this time period has expired.

4.2 Setup

To program the High/Low limits and test parameters press both “▼” and “▲” switch simultaneously to enter the ***“Select Para INC/DEC”*** mode. The first programmable parameter will appear on the display. To increment through the program menus press the “▲” button. To decrement through the menus press the “▼” button. To edit a menu option press both “▼” and “▲” switch simultaneously to enter the ***“Edit Para INC/DEC”*** mode. To increment the parameter press the “▲” button. To decrement the parameter press the “▼” button. To end the ***“Edit Para INC/DEC”*** press both “▼” and “▲” switch simultaneously to exit and return to the normal display mode.

5.0 GAS FLOW SURGE “PEAK” MEASUREMENT

5.1 Description

The GFM has a peak value "sample and hold" feature. This allows the user to measure the maximum gas flow rate, which occurred during the welding cycle. The maximum value is the result of a gas surge, which occurs when the gas solenoid is activated. The trigger used to determine the time at peak is the “Max Limit” value. The time above this level is measured and displayed. Whenever the Flow rate exceeds this value the time is accumulated. When the flow stops the GFM will display the Peak flow and the accumulated time above the max limit. When the flow starts again the values are cleared and new values are displayed.

5.2 Setup

To enable the Peak flow and set the High limits and test parameters press both “▼” and “▲” switch simultaneously to enter the **“Select Para INC/DEC”** mode. The first programmable parameter will appear on the display. To increment through the program menus press the “▲” button. To decrement through the menus press the “▼” button. Until the “Enable Peak?” option is displayed. To edit a menu option press both “▼” and “▲” switch simultaneously to enter the **“Edit Para INC/DEC”** mode. To toggle the option to “YES” press the “▲” button. To end the **“Edit Para INC/DEC”** press both “▼” and “▲” switch simultaneously to exit and return to the normal display mode. The “Peak= ### #.# sec” window will be displayed and the Peak function will be enabled.

6.0 GAS FLOW USAGE LOG

6.1 Description

The GFM has a gas flow volume accumulator and gas flow accumulated timer which can be used to display total gas usage and Total gas flow Time. This function allows the user to measure the total cubic ft. or liters of gas used from the last time that the accumulator was reset. The maximum volume displayed is 6550.0 cubic ft. or cubic Liters. If the usage exceeds this value the accumulator will be reset to 0 and will count up from zero as the usage increases.

6.2 Setup

To enable the Log mode press both “▼” and “▲” switch simultaneously to enter the “**Select Para INC/DEC**” mode. The first programmable parameter will appear on the display. To increment through the program menus press the “▲” button. To decrement through the menus press the “▼” button until the “**Log Mode=**” option is displayed. To edit a menu option press both “▼” and “▲” switch simultaneously to enter the “**Edit Para INC/DEC**” mode. To toggle the option to “**On**” press the “▲” button. To end the “**Edit Para INC/DEC**” press both “▼” and “▲” switch simultaneously to exit and return to the normal display mode. The “**Tot Volume=##.#**” and the “**Total Time=HR:MN:SS**” will be displayed. Where **##.#** is the total accumulated volume and **HR:MN:SS** is the total time of gas flow since the last user reset. Log mode option will be enabled.

NOTE: THE GFM PROVIDES A REASONABLE ESTIMATE OF SHIELDING GAS USAGE. HOWEVER, THIS NUMBER CANNOT BE CONSIDERED TO BE ABSOLUTE SINCE THE GFM DOES NOT MEASURE OR MONITOR OTHER VARIABLES, WHICH MAY HAVE AN AFFECT ON GAS USAGE, SUCH AS PRESSURE AND TEMPERATURE.

6.3 Reset Log mode clock

To reset the Log mode clock press both “▼” and “▲” switch simultaneously to enter the “**Select Para INC/DEC**” mode. The first programmable parameter will appear on the display. To increment through the program menus press the “▲” button. To decrement through the menus press the “▼” button. Until the “**Clear Log Time?**” option is displayed. To edit a menu option press both “▼” and “▲” switch simultaneously to enter the “**Edit Para INC/DEC**” mode. To toggle the option to “**Yes**” press the “▲” button. To end the “**Edit Para INC/DEC**” press both “▼” and “▲” switch simultaneously to exit and return to the normal display mode. The “**Total Time=00:00:00**” will be reset to zero.

6.4 Reset Log mode volume

To reset the Log mode volume press both “▼” and “▲” switch simultaneously to enter the **“Select Para INC/DEC”** mode. The first programmable parameter will appear on the display. To increment through the program menus press the “▲” button. To decrement through the menus press the “▼” button. Until the **“Reset Volume?”** option is displayed. To edit a menu option press both “▼” and “▲” switch simultaneously to enter the **“Edit Para INC/DEC”** mode. To toggle the option to **“Yes”** presses the “▲” button. To end the **“Edit Para INC/DEC”** press both “▼” and “▲” switch simultaneously to exit and return to the normal display mode. The **“Tot Volume = 0.0”** will be reset to zero.

7.0 GFM CONNECTOR PIN ASSIGNMENT

7.1 AUX Connector

The following is the pin out for the AUX Connector.

Pin No.	Function
1 (WHT)	Modbus RS-485 D+ serial port
2 (BRN)	User supplied Power Input VIN+ (12-28 VDC @100 ma)
3 (GRN)	CR-A - Will be active when gas flow is within programmed limits.
4 (YEL)	CR-B – Will be active when gas flow is within programmed limits.
5 (GRY)	User supply power common VCOM
6 (PNK)	Modbus RS485 and Vout analog common
7 (BLU)	Modbus RS-485 D- serial port
8 (RED)	Gas Flow Analog output VOUT+ (0.00 – 2.55 vdc)

8.0 POWER OPTIONS AND BATTERY SPECIFICATION/CHANGING

8.1 Power Options

The GFM can be used as a Battery Powered device or installed in-line and powered from a Plug-in Wall power supply or user supplied 12 - 24 vdc power supply.

8.1.2 Power Board – Revision: A

By default the jumper on Header “JP1” is installed on Location “A” for “Manual” function. This will enable the power switch whenever the battery is being used as the power source.

When the jumper is on Location “B”, this sets the “Auto” function. This disables the power switch for whenever the external power is applied through the Power Connector or Aux Connector keeping the GFM always turned on.

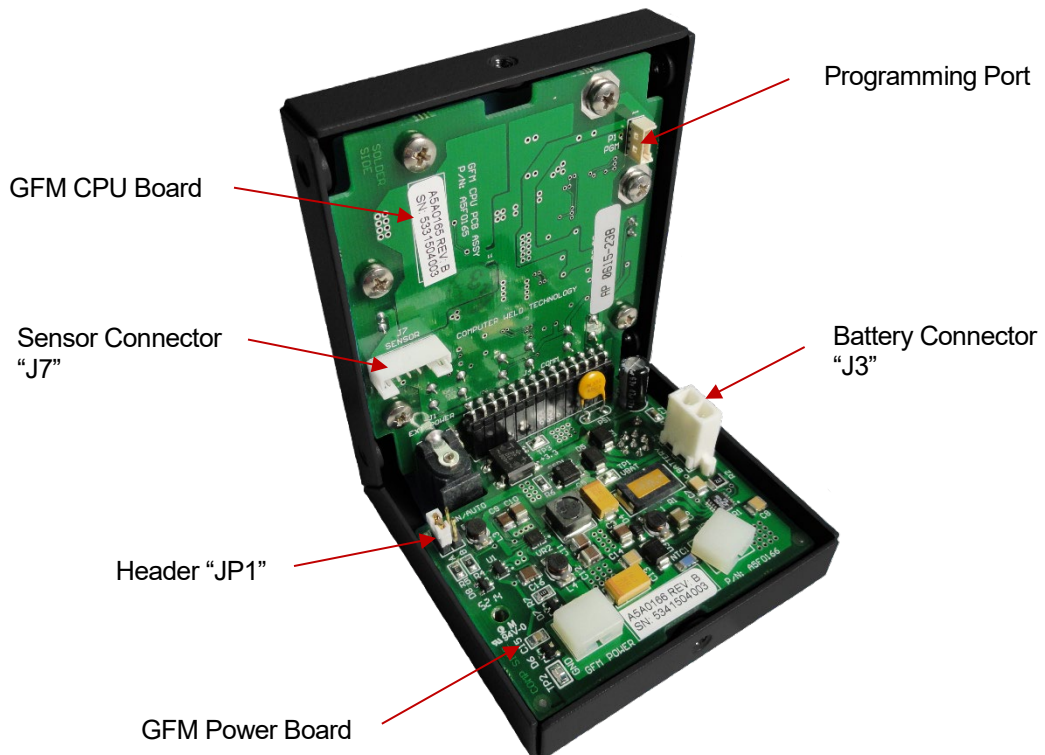

Inside View of GFM Enclosure
(Power Board - Revision: A)

8.2 Battery Specifications

The portable GFM is supplied with an internal, rechargeable battery. The battery will operate the GFM continuously for approximately 24 hours when fully charged. The supplied plug-in the wall transformer will recharge the battery in approximately 8-10 hours. The GFM can be operated while charging the battery. The battery charge status is displayed by the "CHRG" LED. When the LED is on the GFM is charging the Battery or supplying power to the GFM. When the charge is complete the LED is off. The LED will be on until the charge current drops below a C/10 rate or when the float charge timer has expired (22.5 minutes).



8.3 Changing the Battery

1. To open the unit, remove the six screws on the back cover of the unit. Carefully lift the cover off.
2. How to remove the battery:
3. Disconnect the two circuit plug of the battery from J3 Battery Header on the Power Board.
4. Cut the two cable ties holding the battery to the Power Board.
5. How to install the battery:
6. Insert the two new cable ties through the two white cable tie holders on the Power Board.
7. Put the battery on top of the two white cable tie mounts and secure in place with the two cable ties. Trim back the two cable ties.
8. Connect the two circuit plug of the battery to J3 Battery Header on the Power Board.
9. Reinstall the cover and the six screws.

Replacement Part - P/N: 9SM26684 (4.1V rechargeable battery)

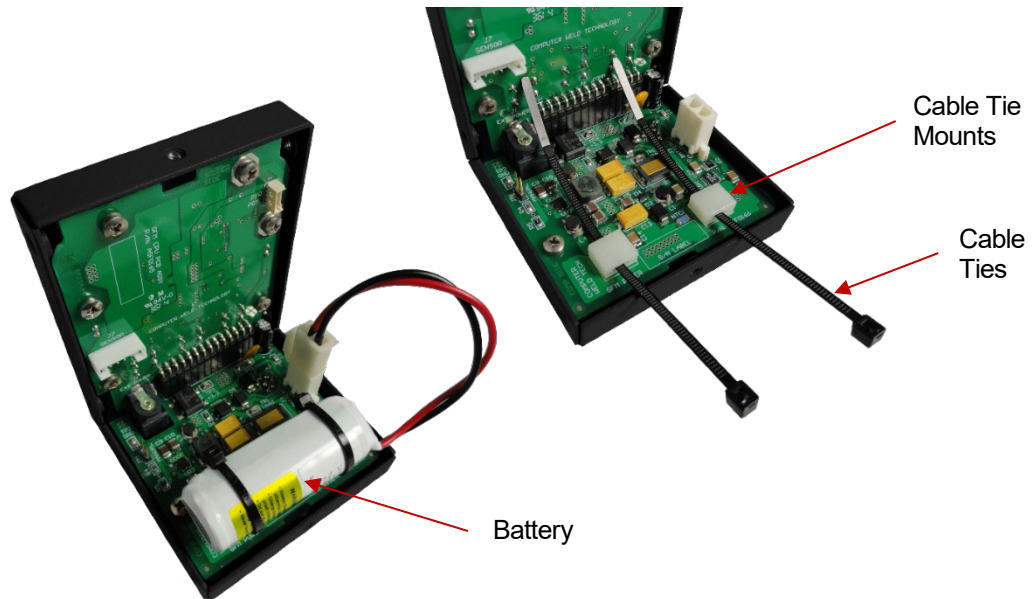

9.0 MODEL SPECIFICATIONS

9.1 120/240 VAC Portable GFM™ System P/N: K3696-1

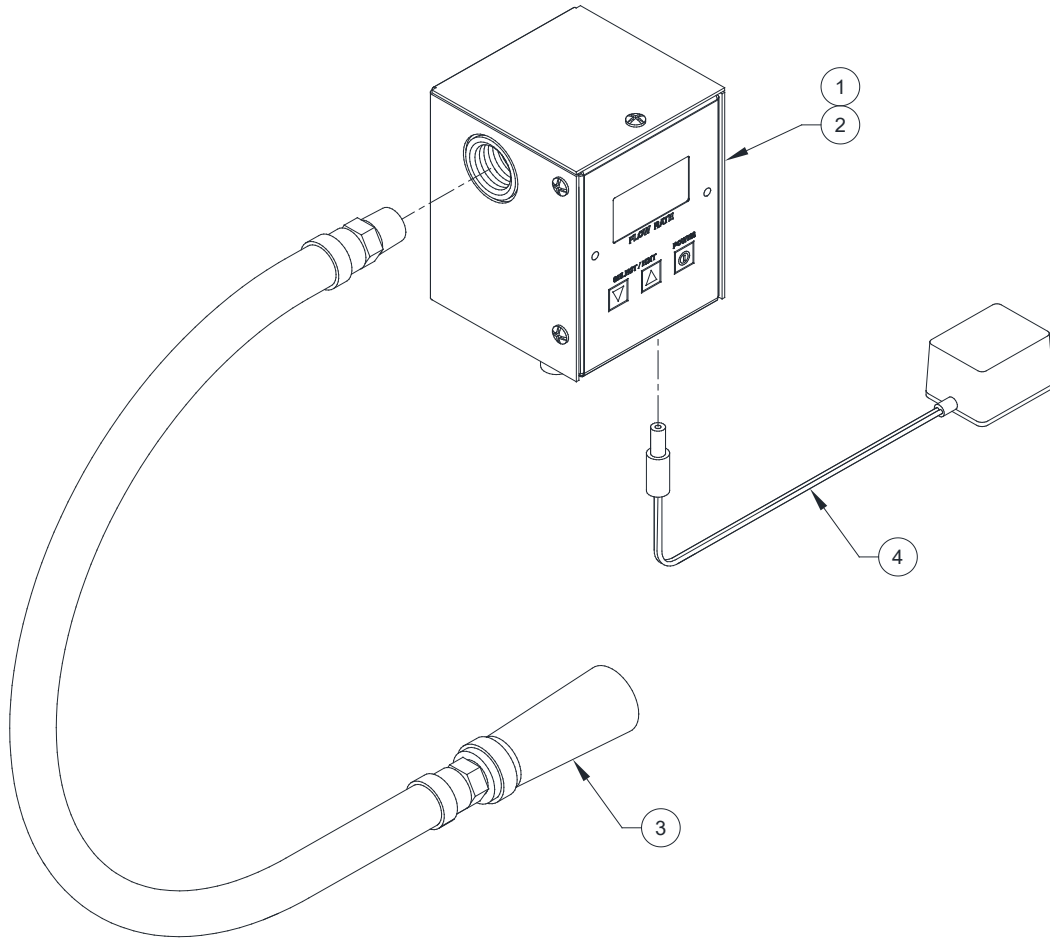

ITEM	QTY	PART NO	DESCRIPTION
1	1	SEE 10.1	GFM Enclosure Assembly
2	1	9SM26684	Rechargeable Battery
3	1	9SM26680	Hose/Cone Assembly
4	1	9SM26676	12VDC Universal Switching Power Supply

NSS – Not Sold Separately

9.2 120/240 VAC In-Line GFM™ System P/N: K3697-1

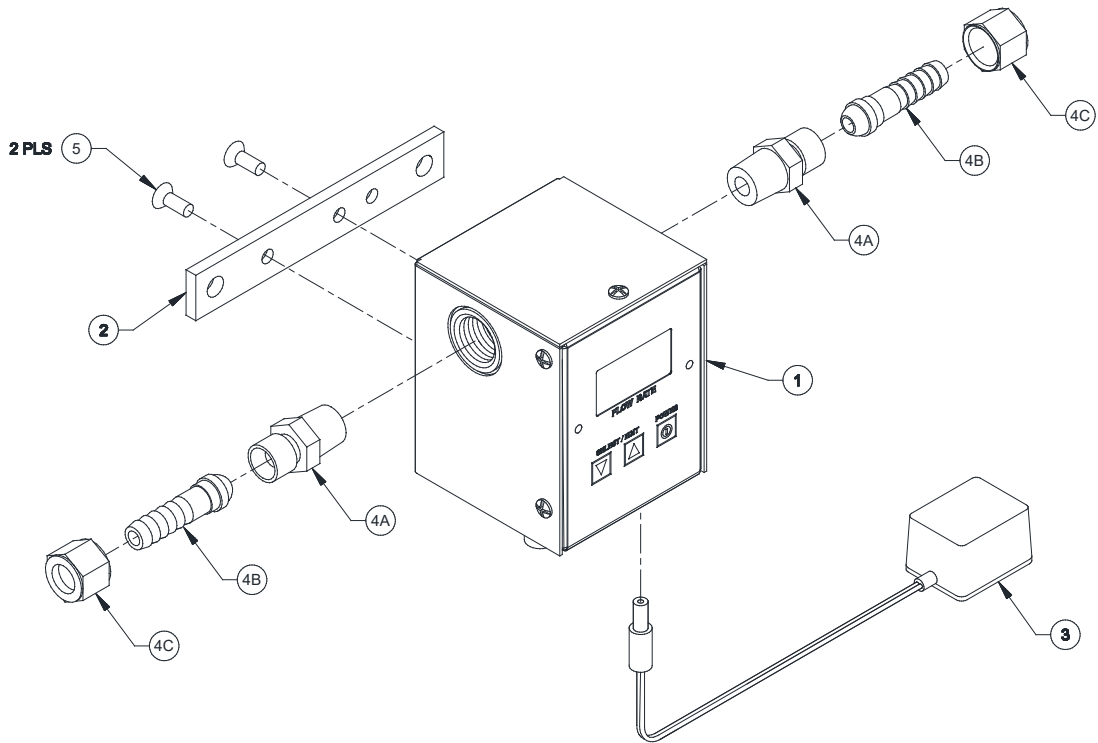

ITEM	QTY	PART NO	DESCRIPTION
1	1	NSS	GFM Enclosure Assembly
2	1	9SM26675	GFM Mounting Bar
3	1	9SM26676	12VDC Universal Switching Power Supply
4	2	9SM26677	Fitting Kit (Contains 4A, 4B and 4C)
4A	2	NSS	Adaptor Fitting
4B	2	NSS	Barb Fitting
4C	2	NSS	"B" Size Nut
5	2	NSS	#10-32 x 1/2" Lg. Socket Flat Hd. Screw

NSS – Not Sold Separately

10.0 GFM ENCLOSURE SPECIFICATIONS

10.1 GFM™ Enclosure Parts List

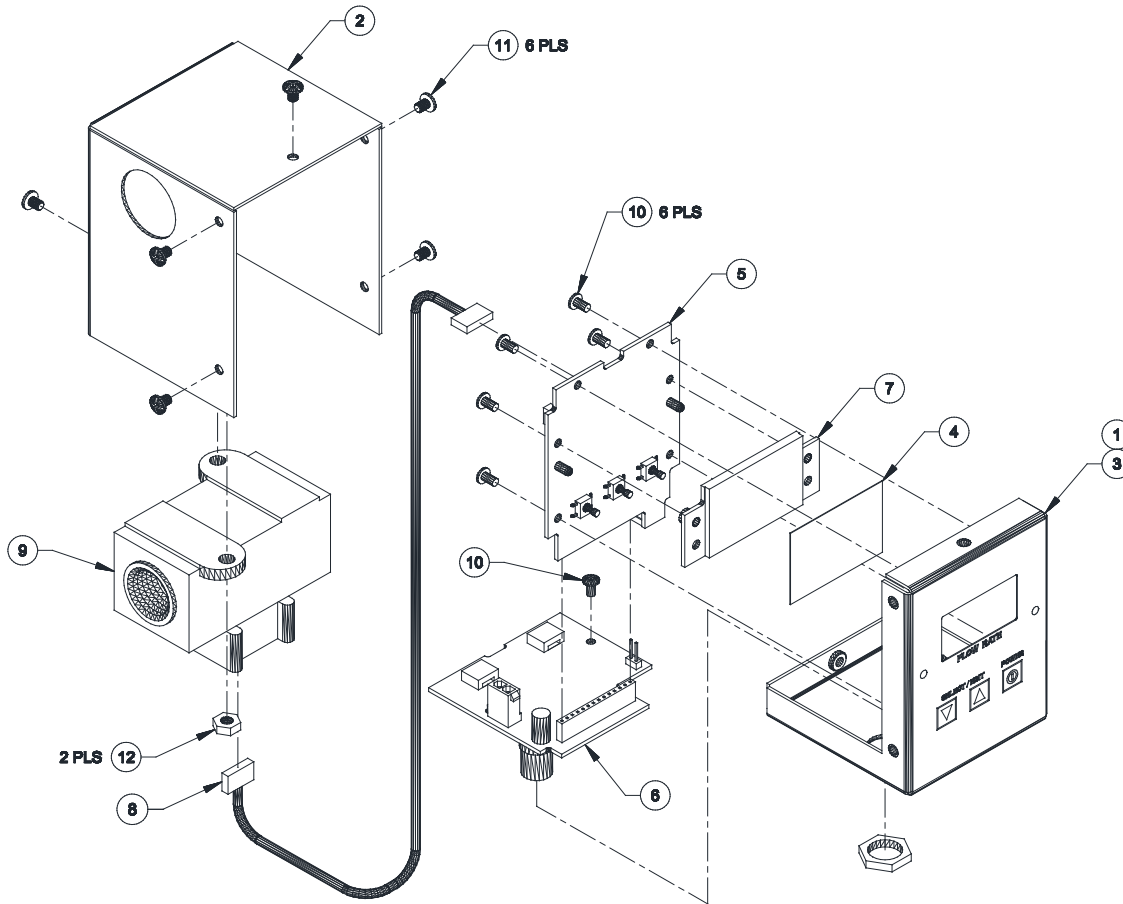

ITEM	QTY	PART NO	DESCRIPTION
1	1	9SM26682	GFM Enclosure Base
2	1	9SM26683	GFM Enclosure Cover
3	1	9SM26681	GFM Enclosure Overlay
4	1	9SM26685	GFM Display Lens
5	1	NSS	GFM CPU PCB Assembly
6	1	NSS	GFM Power PCB Assembly
7	1	NSS	GFM Display PCB Assembly
8	1	NSS	GFM Sensor Harness
9	1	NSS	Airflow Sensor
10	7	NSS	M3 - 0.5 X 6MM Phillips Pan Head Screw
11	6	NSS	#6-32 x 1/4" Pan Head Screw w/ Lock Washer
12	2	NSS	#10-32 Small Pattern Nut

NSS – Not Sold Separately

10.2 GFM™ Mounting Dimensions

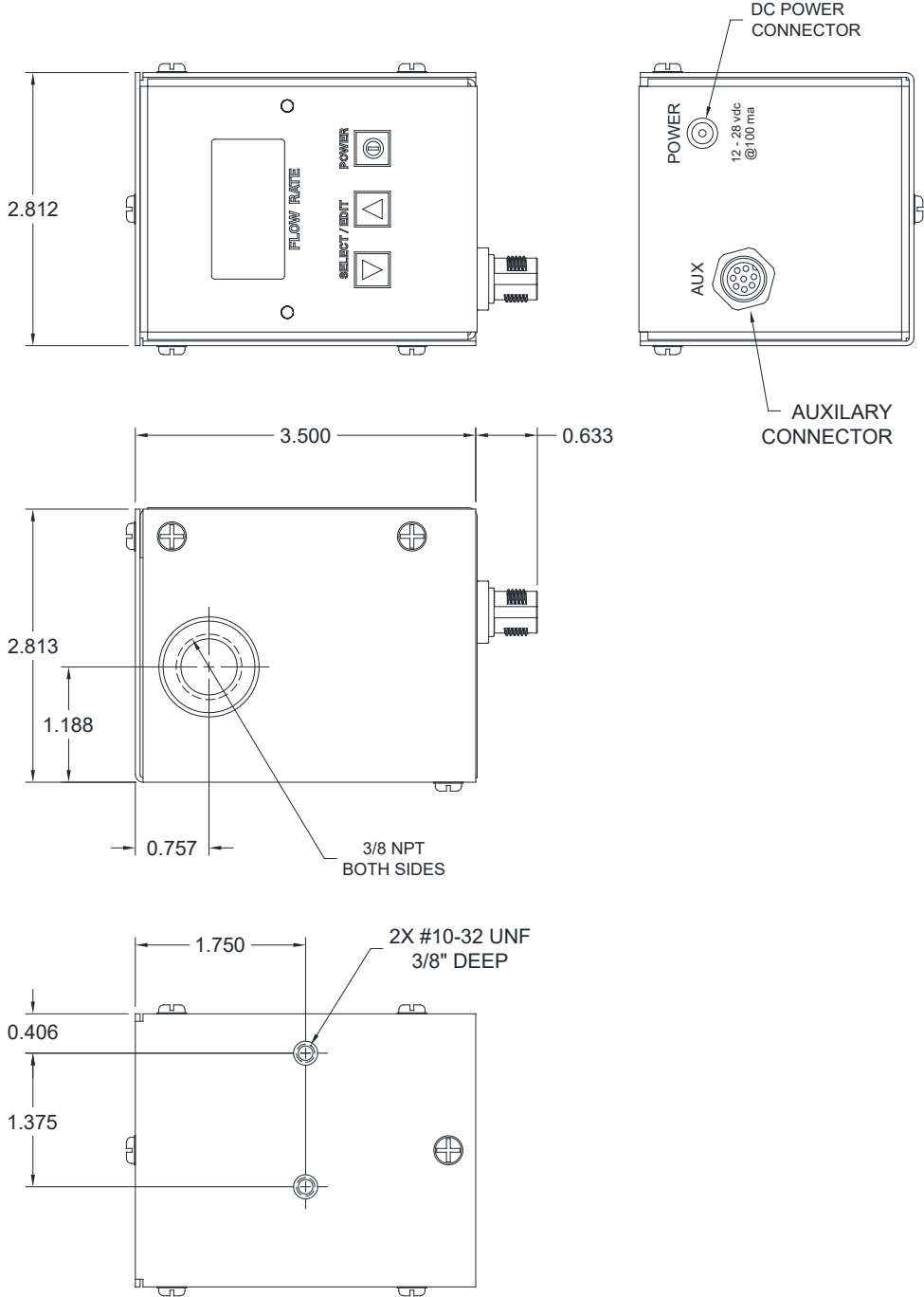

Installation with Threaded Inserts or Free Hanging

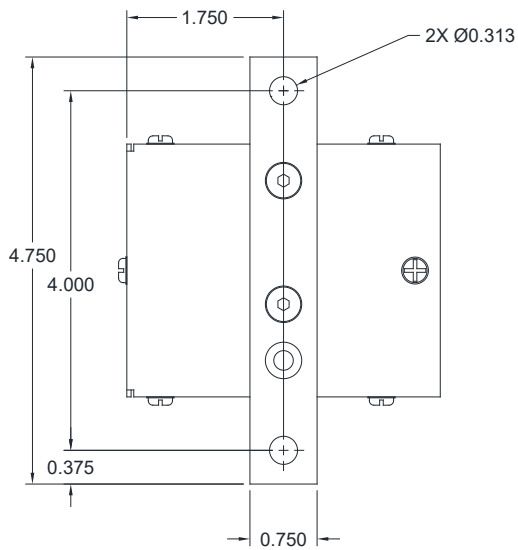
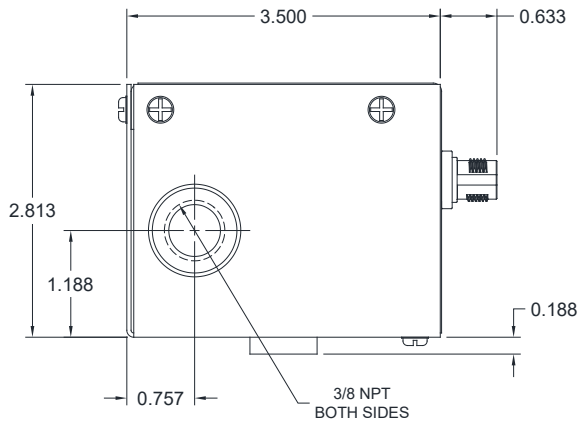
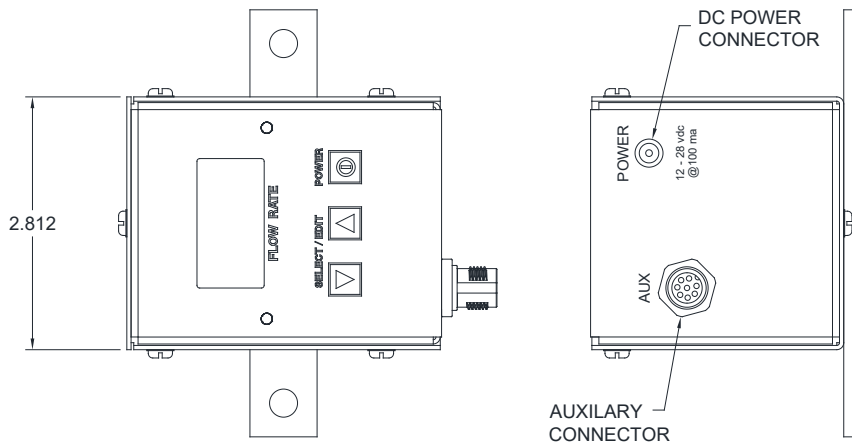

Installation with Mounting Bar

11.0 CABLE SPECIFICATIONS

11.1 GFM™ Aux Cable P/N: K3698-1

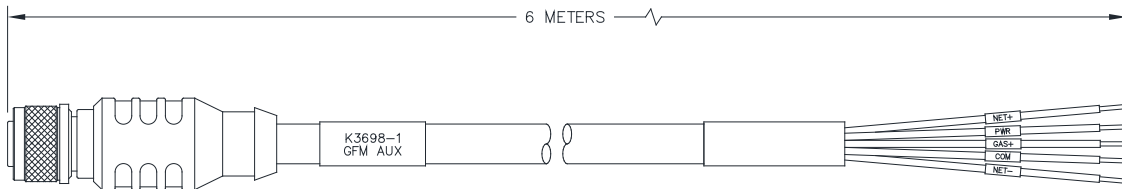

WIRE COLOR	FROM	DESCRIPTION
White	Pin 1	Net+
Brown	Pin 2	Power In (12 – 28 VDC)
Green	Pin 3	Relay CR-A
Yellow	Pin 4	Relay CR-B
Grey	Pin 5	Power Common
Pink	Pin 6	Sensor Vout common
Blue	Pin 7	Net-
Red	Pin 8	Sensor Vout+ (0 – 2.55 VDC)
Shield	Conn Ring	Earth

12.0 MODBUS SPECIFICATIONS

12.1 GFM MODBUS REGISTER DATA

This document provides the basic Modbus memory map and command structure for the GFM RS-485 communications port. The GFM supports the Modbus Protocol as specified in the Modicon Technical publications "Modbus Protocol" (intr7.html). The GFM control does not support the Broadcast mode. The controller provides the slave side communications routines for the RTU mode. The user must set the Slave ID to 1-247 the default ID is set to 1. Default Baud rate is 19.2 K baud with 8 data bits, One Stop and no parity. The following Modbus commands are supported:

CODE	DESCRIPTION	ADDRESS RANGE
01	Read Coil Status	1-49
03	Read Holding Registers	1-124
05	Force Single Coil	1-49
06	Preset Single Register	1-124
15	Force Multiple Coils	1-49
16	Preset Multiple Registers	1-124
17	Report Slave ID	5 bytes

All Modbus Register values are word sized unsigned integer unless otherwise indicate.

12.2 MODBUS COILS CR [1..16]

INPMSK - Simulated Relay Inputs CR [1...8]

- Bit 0 = Enable Log Mode
- Bit 1 = Enable Metric
- Bit 2 = Enable Alarms
- Bit 3 = Reset Volume
- Bit 4 = Reset RTC
- Bit 5 = Spare 1 – Not used
- Bit 6 = Spare 2 – Not used
- Bit 7 = Spare 3 – Not Used

RELMSK - Simulated Outputs CR [9...16]

- Bit 0 = System Ready Output
- Bit 1 = Gas Flow Active
- Bit 2 = Gas Flow Low Limit
- Bit 3 = Gas Flow Ok – Hardware SSR Relay Output
- Bit 4 = Gas Flow High Limit
- Bit 5 = Low Gas Volume level alarm
- Bit 6 = Spare 4 – Not used
- Bit 7 = Spare 5 – Not used

12.3 MODBUS REGISTER REG [1..10]

REG NO.	MNEMONIC	FORMAT	PARAMETER DESCRIPTION
1	GASFLOW	###	Gas flow rate
2	MAXLMT	###	Max Gas Flow Alarm Limit
3	MINLMT	###	Low Gas flow Alarm Limit
4	MINVOL	#####	Low Volume Alarm (Not Enabled)
5	ACCVOL	#####.#	Accumulated Gas Flow since last reset
6	RTCHR	#####	Total Gas Flow hours since last reset
7	RTCMIN:SEC	##.##	Total Minutes (MSB) and Seconds(LSB)
8	PKFLOW	###	Peak Gas flow rate for last Flow period
9	PKTIME	###.##	Peak Flow rate Time for last flow period
10	SPARE1	#####	Spare REG – Not used

12.4 MODBUS SERIAL PORT CONNECTIONS

To use the Modbus communications port the user must connect a suitable RS-485 driver and Modbus host device to the GFM Auxiliary cable K3698-1. Connect the RS-485 driver output “A/(TxD-/RxD-)” to the “BLUE” (Pin 7) wire. Connect the RS-485 driver output “B/(TxD+/RxD+) ” to the WHITE (Pin 1) wire. Connect the RS-485 driver output “COM” to the “PINK” (Pin 6) wire. The RS-485 driver “COM” should also be connected to the user supplied GFM Power Input common.

The following is the pin out for the GFM AUX Cable (P/N: K3698-1).

PIN NO.	WIRE COLOR	FUNCTION
1	WHITE	Modbus RS-485 B(TxD+/RxD+) serial port
2	BROWN	User supplied Power Input VIN+ (12-28 VDC @100 ma)
3	GREEN	CR-A - Will be active when gas flow is within programmed limits.
4	YELLOW	CR-B – Will be active when gas flow is within programmed limits.
5	GREY	User supply power common VCOM
6	PINK	Modbus RS485 and Vout analog common
7	BLUE	Modbus RS-485 A(TxD-/RxD-) serial port
8	RED	Gas Flow Analog output VOUT+ (0.00 – 2.55 vdc)

			
WARNING	<ul style="list-style-type: none"> Do not touch electrically live parts or electrode with skin or wet clothing. Insulate yourself from work and ground. 	<ul style="list-style-type: none"> Keep flammable materials away. 	<ul style="list-style-type: none"> Wear eye, ear and body protection.
Spanish AVISO DE PRECAUCION	<ul style="list-style-type: none"> No toque las partes o los electrodos bajo carga con la piel o ropa mojada. Aíslese del trabajo y de la tierra. 	<ul style="list-style-type: none"> Mantenga el material combustible fuera del área de trabajo. 	<ul style="list-style-type: none"> Protéjase los ojos, los oídos y el cuerpo.
French ATTENTION	<ul style="list-style-type: none"> Ne laissez ni la peau ni des vêtements mouillés entrer en contact avec des pièces sous tension. Isolez-vous du travail et de la terre. 	<ul style="list-style-type: none"> Gardez à l'écart de tout matériel inflammable. 	<ul style="list-style-type: none"> Protégez vos yeux, vos oreilles et votre corps.
German WARNUNG	<ul style="list-style-type: none"> Berühren Sie keine stromführenden Teile oder Elektroden mit Ihrem Körper oder feuchter Kleidung! Isolieren Sie sich von den Elektroden und dem Erdboden! 	<ul style="list-style-type: none"> Entfernen Sie brennbares Material! 	<ul style="list-style-type: none"> Tragen Sie Augen-, Ohren- und Körperschutz!
Portuguese ATENÇÃO	<ul style="list-style-type: none"> Não toque partes elétricas e electrodos com a pele ou roupa molhada. Isole-se da peça e terra. 	<ul style="list-style-type: none"> Mantenha inflamáveis bem guardados. 	<ul style="list-style-type: none"> Use proteção para a vista, ouvido e corpo.
Japanese 注意事項	<ul style="list-style-type: none"> 通電中の電気部品、又は溶材にヒフやぬれた布で触れないこと。 施工物やアースから身体が絶縁されている様にして下さい。 	<ul style="list-style-type: none"> 燃えやすいものの側での溶接作業は絶対にしてはなりません。 	<ul style="list-style-type: none"> 目、耳及び身体に保護具をして下さい。
Chinese 警告	<ul style="list-style-type: none"> 皮肤或湿衣物切勿接触带电部件及焊条。 使你自己与地面和工件绝缘。 	<ul style="list-style-type: none"> 把一切易燃物品移离工作场所。 	<ul style="list-style-type: none"> 佩戴眼、耳及身体劳动保护用具。
Korean 위험	<ul style="list-style-type: none"> 전도체나 용접봉을 젖은 형갑 또는 피부로 절대 접촉치 마십시오. 모재와 접지를 접촉치 마십시오. 	<ul style="list-style-type: none"> 인화성 물질을 접근시키지 마십시오. 	<ul style="list-style-type: none"> 눈, 귀와 몸에 보호장구를 착용하십시오.
Arabic تحذير	<ul style="list-style-type: none"> لا تلمس الاجزاء التي يسري فيها التيار الكهربائي أو الألكترود بجسدك أو بالملابس المبللة بالماء. ضع عازلا على جسمك خلال العمل. 	<ul style="list-style-type: none"> ضع المواد القابلة للاشتعال في مكان بعيد. 	<ul style="list-style-type: none"> ضع أدوات وملابس واقية على عينيك وأذنيك وجسمك.

READ AND UNDERSTAND THE MANUFACTURER'S INSTRUCTION FOR THIS EQUIPMENT AND THE CONSUMABLES TO BE USED AND FOLLOW YOUR EMPLOYER'S SAFETY PRACTICES.

SE RECOMIENDA LEER Y ENTENDER LAS INSTRUCCIONES DEL FABRICANTE PARA EL USO DE ESTE EQUIPO Y LOS CONSUMIBLES QUE VA A UTILIZAR, SIGA LAS MEDIDAS DE SEGURIDAD DE SU SUPERVISOR.

LISEZ ET COMPRENEZ LES INSTRUCTIONS DU FABRICANT EN CE QUI REGARDE CET EQUIPMENT ET LES PRODUITS A ETRE EMPLOYES ET SUIVEZ LES PROCEDURES DE SECURITE DE VOTRE EMPLOYEUR.

LESEN SIE UND BEFOLGEN SIE DIE BETRIEBSANLEITUNG DER ANLAGE UND DEN ELEKTRODENEINSATZ DES HERSTELLERS. DIE UNFALLVERHÜTUNGSVORSCHRIFTEN DES ARBEITGEBERS SIND EBENFALLS ZU BEACHTEN.

			
<ul style="list-style-type: none"> ● Keep your head out of fumes. ● Use ventilation or exhaust to remove fumes from breathing zone. 	<ul style="list-style-type: none"> ● Turn power off before servicing. 	<ul style="list-style-type: none"> ● Do not operate with panel open or guards off. 	WARNING
<ul style="list-style-type: none"> ● Los humos fuera de la zona de respiración. ● Mantenga la cabeza fuera de los humos. Utilice ventilación o aspiración para gases. 	<ul style="list-style-type: none"> ● Desconectar el cable de alimentación de poder de la máquina antes de iniciar cualquier servicio. 	<ul style="list-style-type: none"> ● No operar con panel abierto o guardas quitadas. 	Spanish AVISO DE PRECAUCION
<ul style="list-style-type: none"> ● Gardez la tête à l'écart des fumées. ● Utilisez un ventilateur ou un aspirateur pour ôter les fumées des zones de travail. 	<ul style="list-style-type: none"> ● Débranchez le courant avant l'entretien. 	<ul style="list-style-type: none"> ● N'opérez pas avec les panneaux ouverts ou avec les dispositifs de protection enlevés. 	French ATTENTION
<ul style="list-style-type: none"> ● Vermeiden Sie das Einatmen von Schweißrauch! ● Sorgen Sie für gute Be- und Entlüftung des Arbeitsplatzes! 	<ul style="list-style-type: none"> ● Strom vor Wartungsarbeiten abschalten! (Netzstrom völlig öffnen; Maschine anhalten!) 	<ul style="list-style-type: none"> ● Anlage nie ohne Schutzgehäuse oder Innenschutzverkleidung in Betrieb setzen! 	German WARNUNG
<ul style="list-style-type: none"> ● Mantenha seu rosto da fumaça. ● Use ventilação e exaustão para remover fumo da zona respiratória. 	<ul style="list-style-type: none"> ● Não opere com as tampas removidas. ● Desligue a corrente antes de fazer serviço. ● Não toque as partes elétricas nuas. 	<ul style="list-style-type: none"> ● Mantenha-se afastado das partes moventes. ● Não opere com os painéis abertos ou guardas removidas. 	Portuguese ATENÇÃO
<ul style="list-style-type: none"> ● ヒュームから頭を離すようにして下さい。 ● 換気や排煙に十分留意して下さい。 	<ul style="list-style-type: none"> ● メンテナンス・サービスに取りかかる際には、まず電源スイッチを必ず切して下さい。 	<ul style="list-style-type: none"> ● パネルやカバーを取り外したままで機械操作をしないで下さい。 	Japanese 注意事項
<ul style="list-style-type: none"> ● 頭部遠離煙霧。 ● 在呼吸區使用通風或排風器除煙。 	<ul style="list-style-type: none"> ● 維修前切斷電源。 	<ul style="list-style-type: none"> ● 儀表板打開或沒有安全罩時不準作業。 	Chinese 警告
<ul style="list-style-type: none"> ● 얼굴로부터 용접가스를 멀리하십시오. ● 호흡지역으로부터 용접가스를 제거하기 위해 가스제거기나 통풍기를 사용하십시오. 	<ul style="list-style-type: none"> ● 보수전에 전원을 차단하십시오. 	<ul style="list-style-type: none"> ● 판넬이 열린 상태로 작동치 마십시오. 	Korean 위험
<ul style="list-style-type: none"> ● ابعد رأسك بعيداً عن الدخان. ● استعمل التهوية أو جهاز ضغط الدخان للخارج لكي تبعد الدخان عن المنطقة التي تتنفس فيها. 	<ul style="list-style-type: none"> ● أقطع التيار الكهربائي قبل القيام بأية صيانة. 	<ul style="list-style-type: none"> ● لا تشغيل هذا الجهاز اذا كانت الاغطية الحديدية الواقية ليست عليه. 	Arabic تحذير

LEIA E COMPREENDA AS INSTRUÇÕES DO FABRICANTE PARA ESTE EQUIPAMENTO E AS PARTES DE USO, E SIGA AS PRÁTICAS DE SEGURANÇA DO EMPREGADOR.

使う機械や溶材のメーカーの指示書をよく読み、まず理解して下さい。そして貴社の安全規定に従って下さい。

請詳細閱讀並理解製造廠提供的說明以及應該使用的銀焊材料，並請遵守貴方的有關勞動保護規定。

이 제품에 동봉된 작업지침서를 숙지하시고 귀사의 작업자 안전수칙을 준수하시기 바랍니다.

اقرأ بتمعن وافهم تعليمات المصنع المنتج لهذه المعدات والمواد قبل استعمالها واتبع تعليمات الوقاية لصاحب العمل.

CUSTOMER ASSISTANCE POLICY

The business of The Lincoln Electric Company is manufacturing and selling high quality welding equipment, consumables, and cutting equipment. Our challenge is to meet the needs of our customers and to exceed their expectations. On occasion, purchasers may ask Lincoln Electric for advice or information about their use of our products. We respond to our customers based on the best information in our possession at that time. Lincoln Electric is not in a position to warrant or guarantee such advice, and assumes no liability, with respect to such information or advice. We expressly disclaim any warranty of any kind, including any warranty of fitness for any customer's particular purpose, with respect to such information or advice. As a matter of practical consideration, we also cannot assume any responsibility for updating or correcting any such information or advice once it has been given, nor does the provision of information or advice create, expand or alter any warranty with respect to the sale of our products.

Lincoln Electric is a responsive manufacturer, but the selection and use of specific products sold by Lincoln Electric is solely within the control of, and remains the sole responsibility of the customer. Many variables beyond the control of Lincoln Electric affect the results obtained in applying these types of fabrication methods and service requirements.

Subject to Change – This information is accurate to the best of our knowledge at the time of printing. Please refer to www.lincolnelectric.com for any updated information.



THE LINCOLN ELECTRIC COMPANY

22801 St. Clair Avenue • Cleveland, OH • 44117-1199 • U.S.A.
Phone: +1.216.481.8100 • www.lincolnelectric.com